

- Standard Capacity: 20.000 LT/H (5.280 GAL/H)
- Standard Pressure: 200 BAR (2.900 PSI)
- Standard Power: 132 kW



HIGH-PRESSURE HOMOGENIZER
H.P. PISTON PUMP

INNOVATIVE
MANUFACTURING
Brand

Advantages

- High capacity at low RPM, saving energy
- Efficient homogenization
- Low maintenance costs
- Easy access for maintenance
- Hygienic and ergonomic desing
- Immediate spate parts availability
- Competitive pricing and on time delivers
- Pro-active competent customer service and support
- Suitable for abrasive and high viscosity products

Options

- 2nd stage homogenizing head
- Plungers in ceramic
- Automation and remote control
- Digital pressure gauge
- Variable frequency drive (VFD)
- Inlet pressure gauge
- Aseptic and sanitary version
- ATEX Compliance
- cGMP support and certification

APPLICATION

Dairy



Milk, UHT Milk,
Soy Milk, Oat Milk
Yoghurt, Ayran
Kefir
Ice Cream
Gelato

Labneh, Kashta
Cream Cheese
Mascarpone
Desserts
Milk Powder
Spray Dried Products

Food & Beverage



Fruit Juices
Fruit Concentrate
Aromas / Cloudifiers
Food Emulsions
Ketchup / Tomato Paste
Margarine

Tahina
Hummus
Caramel Sauce
Topping Sauce
Dressing
Peanut / Hazelnut Paste

Chemicals and Petrochemical



Greas
Lubricants
Paraffin Emulsions
Silicone Emulsions
Wax Emulsions
Mineral oil Emulsions

Polymer Suspensions
Fungicides, Herbicides
Latex
Paint
Detergents

Cosmetics



Hair Products
Beauty Creams
Moisturizing Creams
Lotion
Shampoos
Half Conditioners

Nail Polishes
Lipsticks
Toothpaste
Collagen
Perfume
Waxes

Pharmaceuticals



Antibiotics
Creams
Antacids
Tablet Coatings
Liposomes
Ointments

Syrups
Vitamins
Proteins
Gels
Vaccines

Biotechnology



Proteins
Yeast
Vitamins
Bacteria
Enzymes
Liposomes

Viruses
Moss
Probiotics
Microorganisms
Algae
Celluloses

Dimensions

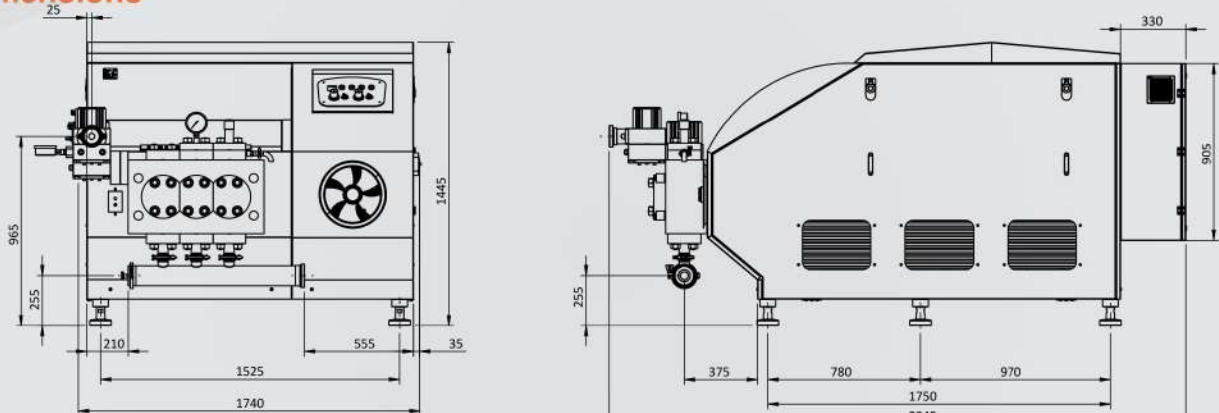

LENGTH mm/in	WIDTH mm/in	HEIGHT mm/in	NET WEIGHT kg/lbs	GROSS WEIGHT kg/lbs	INLET / OUTLET
2945 116	1740 68.5	1445 47	4200 9260	5500 1212.5	DN100 DN65

Measure in mm/in

Compression Head

- Moonblock head formed by single forged block in high quality SS alloy
- 3-D CAD design, engineered using, FEM and CFD Analysis
- INNOTION function integrating technical R&D and technology focus.
- Surface Roughness: Ra<1.6µm, Ra<0.8µm, Ra<0.5µm (electropolished)
- Designed to avoid sharp edges and stress concentration
- Overpressure relief valve installed
- 10-year warranty against cracks and defects

Homogenizing Valve

- Designed to be energy efficient with high stability
- Homogenization pressure pneumatic regulating system
- Tungsten carbide, cobalt carbide, Zirconium ceramic and silicon nitride, solid ceramic available as option

Pump Valves

- Mushroom and ball type in high wear resistant SS alloy
- Stellite and tungsten carbide materials available as option
- Designed symmetrically to be used twice-once on each time

Pump Body (Gearbox)

- High resistant resin reinforced cast iron
- Heavy duty engineered and vibrationless
- AC motor drive through V belts and pulleys with integrated

Frame

- Thick stainless-steel material is used for heavy load

Plungers

- Chrome coated stainless-steel alloy
- Ceramic, HCR chromium and tungsten carbide coated as option
- Solid ceramic as option

Sealing Components

- Long Lasting Food-grade hygienic material
- EPDM, NBR, FKM, PE, PTFE, ZEDEX, PEEK, TIVAR, Kevlar
- Available with FDA approval

Technical Data

Motor Power	110 kW
Number of Plungers	3
Lubrication Oil ISO VG 150	55 L
Gear Reducer Oil ISO VG 320	27 L
Water Consumption	150 L

Performance

Max. Capacity		Max. Pressure	
LT/H	GAL/H	BAR	PSI
25000	6600	170	2500
20000	5280	200	2900
15000	3960	250	3600
12000	3670	300	4350
10000	2640	400	5800
7000	1850	500	7250
5000	1320	750	11000
2500	660	1000	14500
1500	400	1200	17400
1000	260	1500	22000

*Special desing & manufacturing are made for different pressures & capacities.

